

ISDN Unit

(Machine Code: A890)

May 17th, 1999
Subject to change

TABLE OF CONTENTS

1. INSTALLATION.....	A890-1
1.1 INSTALLATION PROCEDURE	A890-1
1.2 USER LEVEL PROGRAMMING.....	A890-3
1.3 SERVICE LEVEL PROGRAMMING	A890-4
2. SERVICE TABLES AND PROCEDURES	A890-5
2.1 SERVICE LEVEL FUNCTIONS	A890-5
2.2 BIT SWITCHES	A890-6
2.2.1 G4 INTERNAL SWITCHES.....	A890-6
2.2.2 G4 PARAMETER SWITCHES.....	A890-14
2.3 DEDICATED TRANSMISSION PARAMETERS	A890-19
3. TROUBLESHOOTING.....	A890-20
3.1 ERROR CODES	A890-20
3.1.1 D-CHANNEL LAYER MANAGEMENT.....	A890-21
3.1.2 D-CHANNEL, LAYER 1	A890-21
3.1.3 D-CHANNEL LINK LAYER	A890-21
3.1.4 D-CHANNEL NETWORK LAYER	A890-22
3.1.5 B-CHANNEL LINK LAYER.....	A890-22
3.1.6 B-CHANNEL NETWORK LAYER	A890-23
3.1.7 TRANSPORT LAYER	A890-23
3.1.8 SESSION LAYER	A890-24
3.1.9 DOCUMENT LAYER	A890-25
3.1.10 PRESENTATION LAYER	A890-25
3.2 G4CCU STATUS CODES	A890-26
3.2.1 LAYER 1 (PHYSICAL LAYER)	A890-26
3.2.2 LAYER 2 (LINK LAYER)	A890-26
3.2.3 NETWORK LAYER (LAYER 3).....	A890-27
3.2.4 TRANSPORT LAYER (LAYER 4).....	A890-27
3.2.5 SESSION LAYER, SESSION CONTROL LAYER (LAYER 5).....	A890-27
3.2.6 SESSION LAYER, DOCUMENT CONTROL LAYER (LAYER 5).....	A890-27
3.3 LEDS	A890-28
3.4 BACK-TO-BACK TEST.....	A890-29

1. INSTALLATION

1.1 INSTALLATION PROCEDURE

⚠ CAUTION

Before installing this option, do the following:

1. Print out all messages stored in the memory, the lists of user-programmed items, and the system parameter list.
2. If there is a printer option in the machine, print out all data in the printer buffer.
3. Turn off the main switch and disconnect the power cord, the telephone line, and the LAN cable.

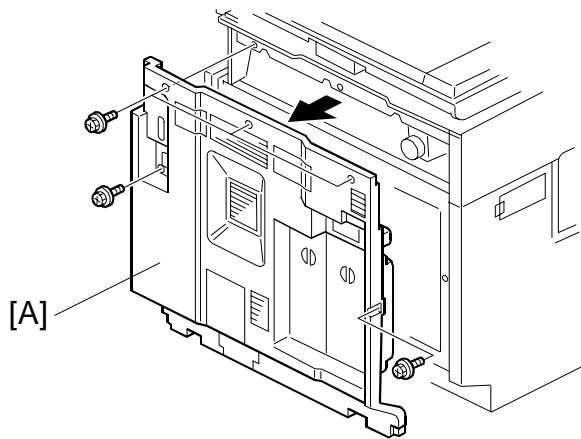

A890I575.WMF

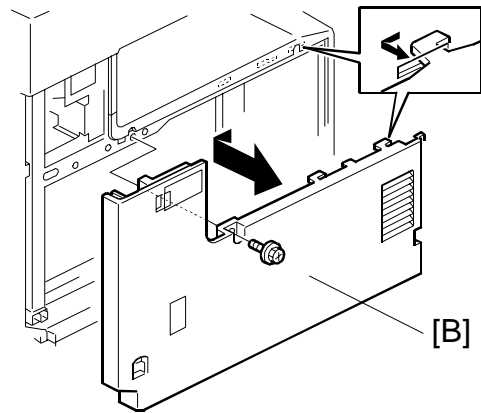

A890I576.WMF

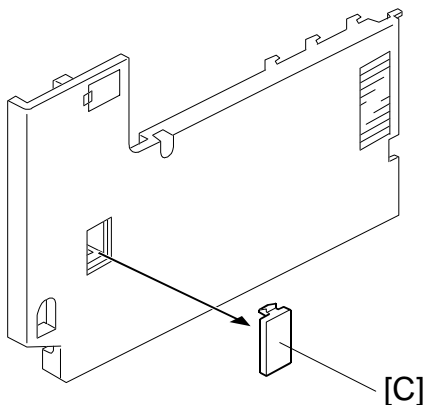

A890I581.WMF

If a printer unit was installed, remove it before installing the ISDN G4 kit.

1. Remove the rear cover [A] (5 screws).
2. Remove the left cover [B], as shown (1 screw).
3. Remove the cover [C] from the left cover.

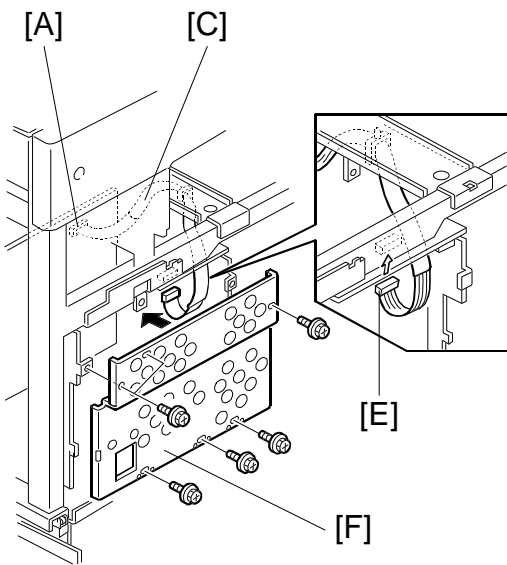

A8901586.WMF

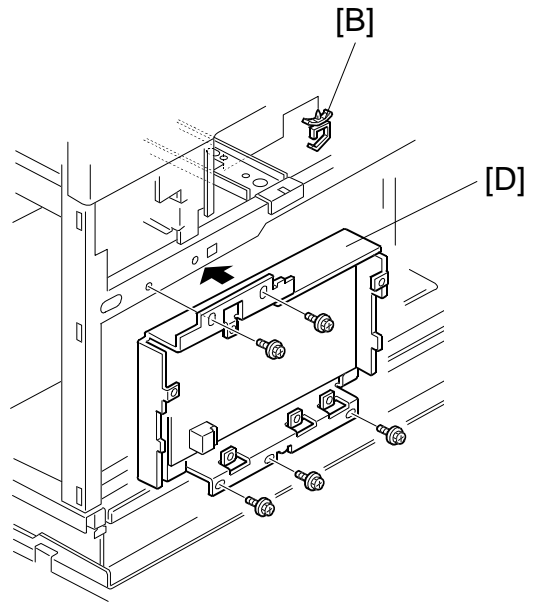

A8901585.WMF

4. Connect the connector [A] to the FCU board.
5. Install the clamp [B] and secure the cable [C] to the clamp.
6. Install the ISDN G4 bracket [D] (5 screws).
7. Connect the connector [E] to the ISDN G4 board.
Note: When connecting the connector [E], pull out the cable [C] to avoid having the printer controller pinch the cable.
8. Install the ISDN G4 board cover [F] (6 screws).
Note: When installing the ISDN G4 board cover, make sure not to pinch the cable [C].
9. Re-install the rear and left covers.
10. Enter SP mode as follows:
 - 1) Press the "Clear Modes" key.
 - 2) Enter "107"
 - 3) Press the "Clear/Stop" key more than 3 seconds.
11. Enter "2" (select "Fax").
12. Enter "01" (select "Bit Switches").
13. Enter "4" (select "Communication Switch").
14. Press the "↑ Switch" key several time and select "Switch 16".
15. Press "2" to change bit 2 from 0 to 1.
16. Exit SP mode and turn the main switch off/on.

1.2 USER LEVEL PROGRAMMING

The following items can be programmed by the key operator. Make sure that the items are programmed correctly.

Item	ISDN		PSTN	Remarks
	G4	G3	G3	
Transfer report: G3 direct number				Used for transfer request operations in G3 PSTN communications
Transfer report: G4 fax number				Used for transfer request operations in ISDN communications
G3 analog line: CSI				Used to identify the terminal in G3 DIS/DCS communications over the PSTN.
G3 digital line: Own fax number1				When not using MSN* service: Program the ISDN subscriber number here. If an another terminal is on the same bus from the DSU, identify the terminals using a sub-address. When using MSN* service: Program the dedicated ISDN number for the terminal as the 1st ISDN subscriber number. If the customer wishes the machine to answer calls to two different numbers, program the second number as the 2nd subscriber no.
G3 digital line: Own fax number2				
G3 digital line: Sub-address				Program a sub-address to identify the terminal, if two or more terminals answer the call to the same subscriber number for G3 fax.
G3 digital line: CSI				Used to identify the terminal in G3 communications over an ISDN.
G4 digital line: Own fax number1				When not using MSN* service: Program the ISDN subscriber number here. If an another terminal is on the same bus from the DSU, identify the terminals using a sub-address. When using MSN* service: Program the dedicated ISDN number for the terminal as the 1st ISDN subscriber number. If the customer wishes the machine to answer the calls to two different numbers, program the second number as the 2nd subscriber no.
G4 digital line: Own fax number2				

G4 digital line: Sub-address				Program a sub-address to identify the terminal, if two or more terminals answer the call to the same subscriber number for G4 fax.
G4 digital line: TID (Terminal ID)				Used to identify the terminal in G4 communications.
Polling ID				Used for secured polling, transfer request operations, and closed network.
Confidential ID				Used for confidential reception. Optional SAF memory required.
RTI				Used to identify the terminal in G3 NSF/NSS communications.
TTI				Printed on each transmitted page in G3 communications.

* MSN = Multiple Subscriber Number; this is also referred to as "Direct Dialing In" in some countries. In this service, more than one number is allocated to one line (one line can have up to 8 units connected to it).

1.3 SERVICE LEVEL PROGRAMMING

Item	Function No.	Remarks
System switches	01 - 1	System Switch 0A - Network used for G3 transmission - Network used for G4-to-G3 fallback
Communication switches	01 - 4	Communication Switch 07 - G4-to-G3 fallback On/Off
G4 internal switches	01 - 6	Change the country code, and reset the machine first. Then change any of the locally required settings and/or the following. Internal Switches 17, 18, 1A, 1B and 1C - G4 to G3 automatic fallback parameters Parameter Switch 01, bits 4 to 6 - Codec attenuation level
G4 parameter switches	01 - 7	

After changing any setting, make sure to turn off the machine, wait for 5 or more seconds, then turn it back on, so that the new settings take effect.

2. SERVICE TABLES AND PROCEDURES

2.1 SERVICE LEVEL FUNCTIONS

Refer to the Fax Unit service manual for how to operate the functions.
Enter SP mode as follows:

- 1) Press the "Clear Modes" key.
- 2) Enter "107"
- 3) Press the "Clear/Stop" key more than 3 seconds.

 → **1** → **0** → **7** → 

- 4) Enter "2" (select "Fax").

Function Number	Description
01	Programming G4 Internal and Parameter Switches
02	Printing G4 System Parameter List
05	G4 Protocol Dump Lists
06	G4 RAM read/write and printing G4 Memory Dump List
11	ISDN G3 CCU tests

2.2 BIT SWITCHES

WARNING

Do not adjust a bit switch or use a setting that is described as "Not used", as this may cause the machine to malfunction or to operate in a manner that is not accepted by local regulations. Such bits are for use only in other areas, such as Japan.

NOTE: After changing any of the switches below, turn off the machine, wait for 5 seconds or more, and turn it back on, so that the new settings take effect.

2.2.1 G4 INTERNAL SWITCHES

Bit Switch 00							
No.	FUNCTION					COMMENTS	
0 to 7	Country code						
	Bit	4	3	2	1	0	Country
		0	0	0	0	0	France
		0	0	0	0	1	Germany (1TR6 mode)
		0	0	0	1	0	UK
		0	0	0	1	1	Italy
		0	0	1	0	0	Austria
		0	0	1	0	1	Belgium
		0	0	1	1	0	Denmark
		0	0	1	1	1	Finland
		0	1	0	0	0	Ireland
		0	1	0	0	1	Norway
		0	1	0	1	0	Sweden
		0	1	0	1	1	Switzerland
		0	1	1	0	0	Portugal
		0	1	1	0	1	Netherlands
		0	1	1	1	0	Spain
		0	1	1	1	1	Israel
		1	0	0	0	1	USA
		1	0	0	1	0	Asia
	1	0	0	1	1	Japan	
	1	0	1	0	0	Hong Kong	
	1	0	1	0	1	South Africa	
	1	0	1	1	0	Australia	
	1	0	1	1	1	New Zealand	
	1	1	0	0	0	Singapore	
	1	1	0	0	1	Malaysia	
Note: In Germany, use the UK setting for the Euro ISDN lines.							

Bit switches 01 and 02 are not used.

Bit Switch 03		
No.	FUNCTION	COMMENTS
0	Amount of protocol dump data in one protocol dump list 0: Last communication only 1: Up to the limit of the memory area for protocol dumping	Change this bit to 0 if you want to have a protocol dump list of the last communication only. This bit is only effective for the dump list #2 (D + Bch1).
1-7	Not used	Do not change the factory settings.

Bit Switch 04		
No.	FUNCTION	COMMENTS
0-4	Not used	Do not change the factory settings.
5	RCBCTR 0: Not valid 1: Valid	This bit is used in Germany; set it to 1 for German PTT approval tests. 1: RCBCTR counts consecutive R:RNR signals. If the counter reaches the value of N2, the link is disconnected.
6-7	Not used	Do not change the factory settings.

Bit Switch 05		
No.	FUNCTION	COMMENTS
0	Not used	Do not change the factory setting.
1	Logical channel number (LCN) 0: Not controlled 1: Fixed at 01	This bit is normally 0. However, some networks may require a fixed LCN. In such cases, this bit should be 1, and you may have to set a different value for the LCN using G4 Parameter Switch 0A.
2	Protocol ID check 0: Yes 1: No	The Protocol ID is in the CR packet.
3-7	Not used	Do not change the factory settings.

Bit Switch 06		
No.	FUNCTION	COMMENTS
0	Inclusion of the DTE address in the S:CR packet 0: No 1: Yes	When the CR packet format matches ISO8208 protocol, some networks may require this bit to be set at 1. This bit is only effective if bit 0 of G4 Parameter switch 06 is at 0.
1	Calling and called DTE addresses 0: Not used 1: Used	This is only for packet networks. The CR packet should contain the rx side's DTE address, but does not have to include the tx side's; it can include it as an option.
2-7	Not used	Do not change the factory setting.

Bit switches 07 and 08 are not used.

Bit Switch 09		
No.	FUNCTION	COMMENTS
0	Not used	Do not change the factory setting.
1	New session within the same call 0: Not accepted 1: Accepted	0: If a new R:CSS is received, the machine sends back S:RSSN. 1: If a new R:CSS is received, the machine sends back S:RSSP. Set this bit to 1 for German PTT approval tests.
2-7	Not used	Do not change the factory settings.

Bit switches 0A to 0F are not used.

Bit Switch 10 (Dch. Layer 1)		
No.	FUNCTION	COMMENTS
0	Connection detector 0: Disabled 1: Enabled	In most countries (including Europe), this should be disabled.
1 2	Layer 1 T3 timer Bit 2 1 Time 0 0 5 s 0 1 29 s 1 0 10 s 1 1 Not used	This should be kept at 5 s (both bits at 0) for normal operation. However, you may have to change this during PTT approval tests.
3	Layer 1 T4 timer 0: Not used 1: Used	Set this bit to 1 for French PTT approval tests.
4-5	Not used	Do not change the factory settings.
6	INFO1 signal resend 0: Resend 1: No resend	0: If there is accidental noise in the INFO1 signal, some DSUs may not reply to the INFO1 signal with INFO2. Try changing this bit to 0, to resend INFO1 before the machine displays "CHECK INTERFACE".
7	Loop back 4 mode 0: Disabled 1: Enabled	This is normally kept at 0. However, set it to 1 for British PTT approval tests.

Bit Switch 11 (Dch. Layer 2)		
No.	FUNCTION	COMMENTS
0	Not used	Do not change the factory setting.
1	Type of TEI used 0: Dynamic TEI 1: Static TEI	This is normally fixed at 0. However, some networks may require this bit to be set at 1 (see below). In this case, you may have to change the values of bits 2 to 7.
2 to 7	Static TEI value	Store the lowest bit of the TEI at bit 7 and the highest bit of the TEI at bit 2. Example: If the static TEI is 011000, set bits 3 and 4 to 1 and bits 2, 5, 6, and 7 to 0.

Bit Switch 12 (Dch. Layer 3)		
No.	FUNCTION	COMMENTS
0-7	Not used	Do not change the factory settings.

Bit Switch 13: D channel layer 3 (Attachment IE in S: SETUP)		
No.	FUNCTION	COMMENTS
0-1	Not used	Do not change the factory settings.
2	Attachment of calling ID 0: No 1: Yes	Normally, this bit should be at 0, because most networks add the calling ID to the SETUP signal to the receiver. However, some networks may require the machine to add this ID. Only in this case should this bit be at 1.
3	Attachment of the Lower Layer Capabilities 0: No 1: Yes	This bit determines whether Lower Layer Capabilities are informed in the [SETUP] signal. Keep this bit at 0 in most cases.
4	Attachment of the Higher Layer Capabilities 0: Yes 1: No	This bit determines whether Higher Layer Capabilities are informed in the [SETUP] signal. Keep this bit at 0 in most cases.
5	Attachment of channel information element (L3 CONN) 0: No 1: Yes	This is normally fixed at 0.
6	Attachment of the Higher Layer Capabilities for ISDN G3 0: Refer to bit 4 1: Not attached	This bit determines whether Higher Layer Capabilities are informed in the [SETUP] signal for ISDN G3 transmission. This switch is effective in coping with communication problems with some types of T/A and PBX which do not respond to Higher Layer Capability "G3." When this bit is set to 0, the setting depends on the setting of bit 4.
7	Not used	Do not change the factory settings.

Bit Switch 14: D channel layer 3 (Selection IE in S: SETUP)		
No.	FUNCTION	COMMENTS
0	ISDN G3 information transfer capability 0: 3.1 kHz audio 1: Speech	In tx mode, this determines the information transfer capability informed in the [SETUP] message. In rx mode, this determines the information transfer capability that the machine can use to receive a call. Set this bit to 1 if the ISDN does not support 3.1 kHz audio. This bit is only used in the USA and the UK.
1-2	Not used	Do not change the factory settings.
3 4	Channel selection in [SETUP] in tx mode Bit 4 3 Setting 0 0 Any channel 0 1 B1 channel 1 0 B2 channel 1 1 Not used	Any channel: When this is informed to the exchanger, the exchanger will select either B1 or B2.
5	Called ID mapping 0: Called party number 1: Keypad facility	0: Called ID is mapped to the called party number. 1: Called ID is mapped to the keypad facility.
6	Numbering plan for the called party number 0: Unknown 1: E.164	E.164: This may be used in Sweden if an AXE10 exchanger is fitted with old software, and in Australia. Unknown: This is the normal setting.
7	Subaddress coding type 0: IA5 (NSAP) 1: BCD (ISO8348)	This is normally kept at 0. However, some networks require this bit to be at 1.

Bit Switch 15: D channel layer 3 (Judgement R: MSG)		
No.	FUNCTION	COMMENTS
0	Action when receiving a [SETUP] signal containing no called subaddress, if the subaddress was included in the dialed number 0: A reply is sent 1: No reply is sent	This bit depends on user requirements. If it is at 1, communication will be halted if the other terminal has not input the subaddress.
1-4	Not used	Do not change the factory settings
5	Global call reference 0: Ignored 1: Global call number is used	Global call reference means 'call reference value = 0'. This bit determines how to deal with such an incoming call if received from the network. Keep this bit at 1 in Germany (1TR6), also in countries where the global call reference is used.
6-7	Not used	Do not change the factory settings.

Bit Switch 16: D channel layer 3 (Approval)		
No.	FUNCTION	COMMENTS
0 1	Answer delay time Bit 1 0 Setting 0 0 No delay 0 1 1.0 s delayed (1TR6) 1 0 0.5 s delayed 1 1 Not used	In Germany (1TR6), a time delay to answer a call is required. In other countries, use this switch as follows: If the machine is connected to the same bus from the DSU as a model K200, the machine receives most of the calls because the response time to a call is faster than the K200. If the customer wants the K200 to receive most of the calls, adjust the response time using these bits. If the customer does not want one machine to receive most of the calls, use subaddresses to identify each terminal.
2	Action when receiving [SETUP] signal containing user-specific called party subaddress 0: Ignores the call 1: Receives the call	Normally, the 3rd octet of called party subaddress information in the [SETUP] signal is set to NSAP. However, some networks may add "user-specific" subaddress to the [SETUP] signal (UK), and the result of this is that the machine won't answer the call if a subaddress is specified. So, change this bit to 1 to let the machine receive the call if the machine is connected to such a network.
3-4	Not used	Do not change the factory settings.
5	Indicated bearer capabilities 0: 56 kbps 1: 64 kbps	1: 64 kbps calling is indicated in the Bearer Capabilities, but communication is at 56 k. Use this bit if the machine is connected to a network which does not accept a 56 kbps data transfer rate as a bearer capability.
6-7	Not used	Do not change the factory settings.

Bit Switch 17: CPS Code Used for G4 to G3 Fallback - 1		
No.	FUNCTION	COMMENTS
0 to 6	Condition for fallback from G4 to G3 Bits 0 to 6 of bit switch 17 contain a CPS code, and bits 0 to 6 of bit switch 18 contain another CPS code. If a CPS code is received which is the same as either of these, communication will fall back from ISDN G4 mode to ISDN G3. The CPS codes must be the same as those specified in table 4-13 of ITU-T recommendation Q.931. Examples: Bit 6 5 4 3 2 1 0 1 0 0 0 0 0 1 CPS code 65 1 0 1 1 0 0 0 CPS code 88	For the codes in bits 0 to 6 to be recognized, bit 7 of bit switch 17 must be 1. Also, bit 0 of Communication Switch 07 must be at 0, or fallback from G4 to G3 will be disabled.
7	This bit determines whether fallback from G4 to G3 occurs on receipt of one of the CPS codes programmed in bit switches 17 or 18, or on receipt of a certain standard code. 0: Fallback occurs on receipt of any of the following CPS codes: UK (EuroISDN mode) - #3, #18, #57, #58, # 63, # 65, #79, #88, and #127 Germany (1TR6 mode) - #3, #31, #53, #58, and #90 Others - #3, #65, and #88 1: Fallback from G4 to G3 occurs on receipt any of above CPS codes or one of the CPS codes programmed in bit switches 17, 18, 1A, 1B, or 1C.	

Bit Switch 18: CPS Code Used for G4 to G3 Fallback - 2		
	FUNCTION	COMMENTS
0 to 6	Condition for fallback from G4 to G3 See the explanation for bits 0 to 6 of bit switch 17	
7	This bit determines the CPS code set for G4 to G3 fallback. 0: Fallback occurs on receipt of the CPS codes specified by bit switch 17 bit 7. 1: The CPS code set depends on bit switch 17, bit 7: If bit switch 17 bit 7 is 0, fallback occurs on receipt of the UK CPS code set (#3, #18, #57, #58, # 63, # 65, #79, #88, and #127) even if another country code is programmed. If bit switch 17 bit 7 is 1, fallback occurs on receipt of the UK CPS code set or one of the CPS codes programmed in bit switches 17, 18, 1A, 1B, or 1C.	

G4 to G3 fallback

Bit 0 of Communication Switch 07 must be at 0, or fallback from G4 to G3 will be disabled.

The CPS codes for which fallback occurs are decided as follows.

- G4 bit switch 17, bit 7 – If set to '0', fallback occurs on receipt of a code from a set that depends on the country code (UK, Germany, or Others). If set to '1', fallback occurs for the 5 CPS codes programmed in bits 0 to 6 of G4 bit switches 17, 18, 1A, 1B, and 1C, in addition to the country code set.

Note that if G4 bit switch 18, bit 7 is set to '1', the country code CPS code set that is used is always the UK set, regardless of the country code setting.

Bit Switch 19		
No.	FUNCTION	COMMENTS
0	Permanence of the link 0: Set/released each LAPD call 1: Permanent	This bit is normally 0, depending on network requirements.
1	Channel used in ISDN L2 (64k) mode 0: B1 1: B2	When making an ISDN L2 back-to-back test, you can select either the B1 or B2 channel with this bit switch.
2	SPID procedure (L2) 0: Disabled 1: Enabled	This is normally fixed at 0.
3	G4 SPID procedure (L2) 0: Disabled 1: Enabled	This is normally fixed at 0.
4-7	Not used	Do not change the factory settings.

Bit Switch 1A: CPS Code Used for G4 to G3 Fallback - 3		
No.	FUNCTION	COMMENTS
0 to 6	Condition for fallback from G4 to G3 See the explanation for bits 0 to 6 of bit switch 17	
7	Not used.	Do not change the setting.

Bit Switch 1B: CPS Code Used for G4 to G3 Fallback - 4		
No.	FUNCTION	COMMENTS
0 to 6	Condition for fallback from G4 to G3 See the explanation for bits 0 to 6 of bit switch 17	
7	Not used.	Do not change the setting.

Bit Switch 1C: CPS Code Used for G4 to G3 Fallback - 5		
No.	FUNCTION	COMMENTS
0 to 6	Condition for fallback from G4 to G3 See the explanation for bits 0 to 6 of bit switch 17	
7	Not used.	Do not change the setting.

Bit switches 1D to 1F are not used. Do not change any of the factory settings.

2.2.2 G4 PARAMETER SWITCHES

Parameter Switch 00		
No.	FUNCTION	COMMENTS
0	Network type	Do not change the default setting.
1	Bit 2 1 0 Type	
2	x 0 0 Circuit switched ISDN Other settings: Not used	
3-7	Not used	Do not change the default settings.

Parameter Switch 01		
No.	FUNCTION	COMMENTS
0	Voice coding 0: μ law 1: A law	0: This setting is used in Japan, Taiwan, and the USA. 1: This setting is used in Europe and Asia.
1	Action when a [SETUP] signal without HLC is received 0: Respond to the call 1: Do not respond to the call	If there are several TEs on the same bus and the machine responds to calls for another TE, the call may be without HLC information. Identify the type of calling terminal and change this bit to 1 if the caller is not a fax machine.
2-3	Not used	Do not change the default settings.
4 5 6	Signal attenuation level for G3 fax signals received from the ISDN line. If an analog signal comes over an digital line, the signal level after decoding by the TE is theoretically the same as the level at the entrance to the digital line. However, this sometimes causes the received signal level to be too high at the received end. In this case, adjust the decoded signal's attenuation level using these switches. The values in the "Codec" column below show the attenuation level at the G4 interface board. The values in the "Modem" column show the actual attenuation level at the modem, because the signal is attenuated again on the FCU by -6dB.	
	Bit 6 5 4 Codec Modem (Actual attenuation level)	
	0 0 0 -4.5dB -10.5dB	
	0 0 1 -2.5dB -8.5dB	
	0 1 0 -0.5dB -6.5dB	
	0 1 1 +1.5dB -4.5dB (default setting)	
	1 0 0 +3.5dB -2.5dB	
	1 0 1 +5.5dB -0.5dB	
	1 1 0 +7.5dB +1.5dB	
	1 1 1 +9.5dB +3.5dB	
7	Not used	Do not change the default settings.

Parameter Switch 02		
No.	FUNCTION	COMMENTS
0	Data rate (kbps)	Other settings: Not used
1	Bit 1 0 Setting	
	0 0 64 kbps 0 1 56 kbps	
2-3	Not used	Do not change the default settings.
4	Transmission mode	Other settings: Not used
5	Bit 5 4 Mode 0 0 CS	
6-7	Not used	Do not change the default settings.

Parameter Switch 03		
No.	FUNCTION	COMMENTS
0	Link modulus 0: 8 1: 128	This setting determines whether protocol frame numbering is done using 3 bits (0 to 7 then start again at 0) or 7 bits (0 to 127 then start again at 0). Set this bit switch to match the network's specifications.
1-7	Not used	Do not change the default settings.

Parameter Switch 04 is not used. Do not change any of the default settings.

Parameter Switch 05		
No.	FUNCTION	COMMENTS
0	Link timer (D-channel layer	The link timer is the maximum allowable time between sending a protocol frame and receiving a response frame from the remote terminal.
1	2 T1 timer)	
2	Bit 3 2 1 0 Value	
3	0 0 0 0 0 s	
	0 0 0 1 1 s	
	0 0 1 0 2 s	
	and so on until	
	0 0 1 0 10 s	
4-7	Not used	Do not change the default settings.

Parameter Switch 06		
No.	FUNCTION	COMMENTS
0	Layer 3 protocol 0: ISO8208 1: T.70NULL	Set this bit to match the type of layer 3 signalling used by the ISDN. The dedicated parameters have the same setting for specific destinations.
1-3	Not used	Do not change the default settings.
4	Packet modulus 0: 8 1: 128	Do not change the default setting, unless the machine is experiencing compatibility problems.
5-7	Not used	Do not change the default settings.

Parameter Switch 07		
No.	FUNCTION	COMMENTS
0	Packet size	This value is sent in the CR packet. This value must match the value stored in the other terminal, or communication will stop (CI will be returned). If the other end returns CI, check the value of the packet window size with the other party. Note that this value must be the same as the value programmed for the transport block size (G4 Parameter Switch B, bits 0 to 3). Normally, do not change the default setting.
1	Bit 3 2 1 0 Value	
2	0 1 1 1 128	
3	1 0 0 0 256	
	1 0 0 1 512	
	1 0 1 0 1024	
	1 0 1 1 2048	
4-7	Not used	Do not change the default settings.

Parameter Switch 08		
No.	FUNCTION	COMMENTS
0	Packet window size	This is the maximum number of unacknowledged packets that the machine can send out before having to pause and wait for an acknowledgement from the other end. This should be kept at 7 normally. If the packet modulus (G4 Parameter Switch 6, bit 4) is 8, the packet window size cannot be more than 7. However, if the packet modulus is 128, the window size can be up to 15. Also, if the layer 3 protocol setting (G4 Parameter Switch 6, bit 0) is at IS8208, the packet window size cannot be more than 7.
1	Bit 3 2 1 0 Value	
2	0 0 0 1 1	
3	0 0 1 0 2	
	and so on until	
	1 1 1 1 15	
4-7	Not used	Do not change the default settings.

Parameter Switch 09		
No.	FUNCTION	COMMENTS
0	LCGN	Keep the value of the LCGN at 0.
1	Bit 3 2 1 0 Value	
2	0 0 0 0 0	
3	0 0 0 1 1	
	0 0 1 0 2	
	and so on until	
	1 1 1 1 15	
4-7	Not used	Do not change the default settings.

Parameter Switch 0A		
No.	FUNCTION	COMMENTS
0	LCN	Normally, keep at the value of the LCN at 1.
1	Bit 7 6 5 4 3 2 1 0 Value	
2	0 0 0 0 0 0 0 1 1	
3	0 0 0 0 0 0 1 0 2	
4	0 0 0 0 0 0 1 1 3	
5	and so on until	
6	1 1 1 1 1 1 1 1 255	
7		

Parameter Switch 0B		
No.	FUNCTION	COMMENTS
0	Transport block size	This value must match the value set in the other terminal. Note that this value must be the same as the value programmed for the packet size (G4 Parameter Switch 7, bits 0 to 3). Also, the transport block size is limited by the amount of memory in the remote terminal.
1	Bit 3 2 1 0 Value	
2	0 1 1 1 128	
3	1 0 0 0 256	
	1 0 0 1 512	
	1 0 1 0 1024	
	1 0 1 1 2048	
4-7	Not used	Do not change the default settings.

Parameter Switch 0C is not used. Do not change any of the default settings.

Parameter Switch 0D		
No.	FUNCTION	COMMENTS
0	Back-to-back test mode	When doing a back-to-back test or doing a demonstration without a line simulator, use these bits to set up one of the machines in TE mode, and the other in NT mode. After the test, return both bits to 0. See "Back-to-back Testing" in the Troubleshooting section for full details.
1	Bit 1 0 Setting	
	0 0 Off	
	0 1 Not used	
	1 0 ISDN L2 test mode (TE mode)	
	1 1 ISDN L2 test mode (NT mode)	
2-7	Not used	Do not change the default settings.

Parameter Switch 0E		
No.	FUNCTION	COMMENTS
0	Troubleshooting mode - real time status codes display 0: Off 1: On	If this is switched on, the status codes will be displayed in the lower two lines of the LCD. Change this bit back to 0 after testing.
1	Saving frames to the protocol dump list 0: Off 1: On	Keep this bit at 1 normally.
2-7	Not used	Do not change the default settings.

2.3 DEDICATED TRANSMISSION PARAMETERS

The following G4 communication parameter bytes have been added for each Quick Dial and Speed Dial. For how to program Dedicated Transmission Parameters, refer to the Service Manual for the base fax unit.

Switches 01 to 04 are for use with Group 3 communication and are explained in the Service Manual for the base fax unit. Switches 5, 6, and 10 are not used.

Switch 07	
No.	FUNCTION
0	Data rate Bit 3 2 1 0 Setting
1	0 0 0 0 064 kbps
2	0 0 0 1 156 kbps
3	1 1 1 1 As in Parameter Switch 2, bits 0 and 1 Other settings: Not used
4-7	Not used

Switch 08	
No.	FUNCTION
0	Link modulus Bit 3 2 1 0 Setting
1	0 0 0 0 Modulo 8
2	0 0 0 1 Modulo 128
3	1 1 1 1 As in Parameter Switch 3, bit 0 Other settings: Not used
4-7	Not used

Switch 09	
No.	FUNCTION
0	Layer 3 protocol Bit 3 2 1 0 Setting
1	0 0 0 0 IS8208
2	0 0 0 1 T.70 NULL
3	1 1 1 1 As in Parameter Switch 6, bit 0 Other settings: Not used
4	Packet modulus Bit 7 6 5 4 Setting
5	0 0 0 0 Modulo 8
6	0 0 0 1 Modulo 128
7	1 1 1 1 As in Parameter Switch 6, bit 4 Other settings: Not used

3. TROUBLESHOOTING

3.1 ERROR CODES

The tables on the following pages show the error codes that will be printed on the Service Monitor Report. See the service manual for the base fax unit for instructions on how to print this report.

The meaning of the numbers in the Action column is as follows.

1. Check Layer 1 signalling with a protocol analyzer to determine the cause of the problem. This may require assistance from a G4 specialist.
2. Repeat the communication. If the problem does not repeat itself, the problem was a temporary one caused by the user connecting the machine to another interface. However, if the problem remains, there is a network problem.
3. There is a network problem.
4. There is a network problem. Do the following:
 - Check the error bit rate of the network. If it is high, contact the network and ask them to improve the line.
 - Check the network speed (is it 56 or 64 kbps), and make sure that the bit switch setting is correct. You may also use the dedicated transmission parameters if this problem only occurs when dialling certain numbers.
 - Check that the user dialled the correct number.
5. There is a network problem, or a problem in the machine at the other end.
6. There is a problem in the machine at the other end; ask a technician to check it.
7. The machine at the other end is not a Group 4 fax terminal.
8. The machine is not compatible with the machine at the other end. A compatibility test is needed.

Error codes related to the errors detected by the FCU are listed in the service manual for the main fax unit.

3.1.1 D-CHANNEL LAYER MANAGEMENT

Code	Probable Cause	Action
7-00	Link reset	2
7-01	Link set-up failed because of a time-out	2
7-02	Link release failed because of a time-out	2
7-03	Link set-up parameter error	2

3.1.2 D-CHANNEL, LAYER 1

Code	Probable Cause	Action
7-10	T3 timeout (layer 1 activation error)	1
7-11	No connection on the S0 interface	1
7-12	Deactivated	1

3.1.3 D-CHANNEL LINK LAYER

Code	Probable Cause	Action
7-20	At the start of link set-up, the machine received an unsolicited S (F=1)	2
7-21	At the start of link set-up, the machine received an unsolicited DM (F=1)	2
7-22	At TEI release, the machine received an unsolicited UA (F=1)	2
7-23	At the start of link set-up, the machine received an unsolicited DM (F=0)	2
7-24	At TEI release, the machine received an unsolicited UA (F=0)	2
7-25	SABME received at the start of network link set-up	No error
7-26	N200 retransmission error for SABME	2
7-27	N200 retransmission error for DISC	2
7-28	N200 retransmission error for situation enquiry (RR)	2
7-29	N(R) sequence number error	3
7-30	N(S) sequence number error	3
7-31	FRMR received	3
7-32	Non-standard frame received	3
7-33	Abnormal frame length	3
7-34	N201 error; information field N in the I frame exceeded N201	3
7-35	T201 timeout; timeout while waiting for checking	3
7-36	T202 timeout; timeout while waiting for ID assignment	3

3.1.4 D-CHANNEL NETWORK LAYER

Code	Probable Cause	Action
7-40	Insufficient mandatory information elements	3
7-41	Abnormal LI for a mandatory information element	3
7-42	T301 timeout; timeout while waiting for R:CONN	3
7-43	T303 timeout; timeout while waiting for R:CALL-PROC etc.	3
7-44	T304 timeout; timeout while waiting for R:CALL-PROC etc.	3
7-45	T305 timeout; timeout while waiting for R:REL	3
7-46	T308 timeout; timeout while waiting for R:REL-COMP	3
7-47	T310 timeout; timeout while waiting for R:ALERT etc.	3
7-48	T313 timeout; timeout while waiting for R:CONN-ACK	3
7-49	Internal error	3
7-51	Release call reference during communication	3

3.1.5 B-CHANNEL LINK LAYER

Code	Probable Cause	Action
7-60	T3 timeout; timeout while waiting for flag	4
7-61	T3 timeout; timeout while waiting for SABM during an incoming call	4
7-62	T1 timeout x N2; timeout while waiting for UA after sending SABM	5
7-63	T1 timeout x N2; timeout while waiting for a response to a transmitted S frame (P=1)	5
7-64	T1 timeout x N2; timeout while waiting for SABM or DISC after sending FRMR	5
7-65	T1 timeout x N2; timeout while waiting for a response to DISC	5
7-66	RNR x N2 (other end busy, RCB counter error)	5
7-67	Invalid (Ad) frame received	5
7-68	Invalid short frame received	5
7-69	Link reset error	5
7-70	FRMR received	5
7-71	Non-standard (Cn) frame received	5
7-72	An S or U frame having an information field was received	5
7-73	A frame longer than the maximum N1 length was received	5
7-74	An S or I frame having an N(R) error was received	5
7-75	CRC error	3

3.1.6 B-CHANNEL NETWORK LAYER

Code	Probable Cause	Action
7-80	A packet having an abnormal GFI was received	6
7-81	A packet was received that had a logical channel number different from the logical channel being used for the communication	6
7-82	A packet containing a format error was received	6
7-83	A packet containing an LI error was received	7
7-84	A CN packet was received that had a PID different from 02	7
7-85	Unsupported packet type received	7
7-86	Abnormal or unsupported facility received	7
7-87	P(s) sequence number error	6
7-88	P(r) sequence number error	6
7-89	A reset using S:RQ or R:RI occurred	6
7-90	A restart using S:RQ or R:SI occurred	6
7-91	Call set-up error; in reply to S:CR, R:CI was received to indicate rejection of the call	7
7-92	T20 timeout; timeout while waiting for an SF packet	6
7-93	T21 timeout; timeout while waiting for a CC packet	6
7-94	T22 timeout; timeout while waiting for an RF packet	6
7-95	T23 timeout; timeout while waiting for a CF packet	6
7-96	T10 timeout; timeout while waiting for the first frame	6

3.1.7 TRANSPORT LAYER

Code	Probable Cause	Action
8-00	Invalid block received	8
8-01	TCC block received	8
8-02	TBR block received	8
8-05	TCR block; block format error	8
8-06	TCR block; block size parameter LI error	8
8-07	TCR block; extended addressing LI error	8
8-08	TCR block; block size length error	8
8-10	TCA block; block format error	8
8-11	TCA block; Tx origin reference data in TCR disagreed with the address reference data in TCA	8
8-12	TCA block; octet 7 did not equal 0	8
8-13	TCA block; extended addressing LI error	8
8-14	TCA block; block size exceeded that set by TCR	8
8-15	TCA block; block size parameter LI error	8
8-20	TDT block; block format error	8
8-21	TDT block; octet 3 did not equal either 00 or 80(H)	8
8-22	TDT block; the end indicator was "Continue" even though there was no field data	8

Code	Probable Cause	Action
8-23	TDT block; an end block with no field data was received after an end indicator of "End"	8
8-26	Timeout during state 0.2	8
8-27	Timeout during state 1.1	8
8-28	Timeout during state 0.3	8

3.1.8 SESSION LAYER

Code	Probable Cause	Action
8-30	Invalid frame received	8
8-31	RSSN received	8
8-32	CSA received	8
8-34	Calling terminal identification error in CSS	8
8-35	Date and time error in CSS	8
8-36	Window size error in CSS	8
8-37	Service identification error in CSS	8
8-38	Session user data error in CSS	8
8-39	CSS rejected (new session rejected)	8
8-40	Called terminal identification error in RSSP	8
8-41	Date and time error in RSSP	8
8-42	Date and time in RSSP was not the same as that in CSS	8
8-43	Window size error in RSSP	8
8-44	Service identification error in RSSP	8
8-45	<%2>Session user data error in <%0>RSSP	8
8-47	Message synchronization error inside the CCU	8
8-48	Document task busy	8
8-50	Ti timeout; non-communication surveillance timer (T.62)	8
8-51	T2 timeout; timeout while waiting for a response (T.62)	8
8-52	T3 timeout; CSA timer timeout (T.62)	8
8-53	G4 board load timer timeout; calling side waited too long for a new session	8
8-54	G4 board load timer timeout; calling side waited too long for transport probability	8
8-55	G4 board load timer timeout; called side waited too long for S:RSSP	8
8-56	G4 board load timer timeout; document transmission surveillance timer timeout	8
8-57	G4 board load timer timeout; timeout while waiting for a user abort request after a provider fail	8

3.1.9 DOCUMENT LAYER

Code	Probable Cause	Action
8-60	T.62 coding format error (LI error)	8
8-61	A mandatory PI was absent, or the LI for a mandatory PI was 0	8
8-62	Calling/called terminal identification LI was different from that specified by F.184 (LI = 24)	8
8-63	The LI for session user data exceeded the maximum value (512)	8
8-64	The LI for CDUI was not 0	8
8-65	Checkpoint and document reference numbers LI error, or they were not in T.61 (ASCII) coding	8
8-66	The checkpoint reference number differed from the expected value	8
8-70	RDGR received	8
8-71	A non-standard PDU was received while in calling mode	8
8-72	A non-standard PDU was received while in called mode	8
8-73	Abnormal PDU received while in calling state ds1	8
8-74	15 consecutive CDCL signals received	8
8-75	Session window size control error (size not equal to 0)	8
8-76	Internal error	8

3.1.10 PRESENTATION LAYER

Code	Probable Cause	Action
8-80	X.209 coding error in session user data (LI error)	8
8-81	PV error in session user data	8
8-82	PI error in session user data	8
8-83	The capabilities in the session user data of CDS/CDC were not the same as those in RDCLP	8
8-84	X.209 coding error in the DP (LI error)	8
8-85	X.209 coding error in the SLD (document descriptor/page descriptor) (LI error)	8
8-86	SLD object type absent	8
8-87	PI error in the SLD (document descriptor/page descriptor)	8
8-88	The capabilities in the SLD (document descriptor/page descriptor) are duplicated or are not the same as those in RDCLP	8
8-89	No document descriptor at the start of the document	8
8-90	No page descriptor at the start of the page	8
8-91	Page descriptor PV error	8
8-92	X.209 coding error in the TU (LI error)	8
8-93	The TU was absent	8
8-94	PV error in the TU	8
8-95	TI error	8
8-96	X.209 coding nest level >> 8, or an LI form error	8
8-97	CDPB/CDE received while TU/TI not yet completed, or an unexpected PDU was received while analyzing an SLD	8

3.2 G4CCU STATUS CODES

The display of G4CCU status codes is affected by the Real Time Display On/off setting (G4 Parameter Switch E, bit 0).

- If Real Time Display is off (the bit is 0; this is the default setting), there is no indication on the operation panel.
- If Real Time Display is on (the bit is 1), the codes are fully displayed on the operation panel.

The codes are defined in the following pages.

3.2.1 LAYER 1 (PHYSICAL LAYER)

Code (H)	Status	Code (H)	Status
10	Ready	E0	R: [DISC]
01	S: [SETUP]	E1	S: [REL]
02	R: [CALL_PROC]	E3	R: [REL_COMP]
03	R: [CONN]	E4	R: [STAT]
04	S: [CONN_ACK]	E5	R: [STAT_ENQ]
05	R: [SETUP_ACK]	F0	S: [DISC]
06	R: [ALERT]	F1	R: [REL]
11	R: [SETUP]	F2	S: [REL_COMP]
12	S: [CALL_PROC]	F3	S: [STAT]
13	S: [CONN]		
14	R: [CONN_ACK]		

3.2.2 LAYER 2 (LINK LAYER)

Code (H)	Status	Code (H)	Status
20	S: SABM, or R: SABM	D0	S: DISC, or R: DISC
21	S: UA, or R: UA	D1	S: DM, or R: DM
22	S: FRMR, or R: FRMR		
28	S: SABME, or R: SABME		

3.2.3 NETWORK LAYER (LAYER 3)

Code (H)	Status	Code (H)	Status
30	S: CR	C2	S: SQ
31	R: CC	C3	R: SF
38	R: CN	CA	R: SI
39	S: CA	CB	S: SF
32	S: GF	C4	S: RQ
3A	R: GQ	C5	R: RF
3B	R: GF	CC	R: RI
C0	S: CQ	CD	S: RF
C1	R: CF	C6	R: IT
C8	R: CI	C7	R: IF
C9	S: CF	CE	R: DIAG

3.2.4 TRANSPORT LAYER (LAYER 4)

Code (H)	Status	Code (H)	Status
40	S: TCR, or R: TCR	42	S: TBR, or R: TBR
41	S: TCA, or R: TCA	43	S: TCC or R: TCC

3.2.5 SESSION LAYER, SESSION CONTROL LAYER (LAYER 5)

Code (H)	Status	Code (H)	Status
50	S: CSS, or R: CSS	56	S: RSUI, or R: RSUI
51	S: RSSP, or R: RSSP	A0	S: CSA, or R: CSA
52	S: RSSN, or R: RSSN	A1	S: RSAP, or R: RSAP
53	S: CSCC, or R: CSCC	A2	S: CSE, or R: CSE
54	S: RSCCP, or R: RSCCP	A3	S: RSEP, or R: RSEP

3.2.6 SESSION LAYER, DOCUMENT CONTROL LAYER (LAYER 5)

Code (H)	Status	Code (H)	Status
60	S: CDCL, or R: CDCL	90	S: CDE, or R: CDE
61	S: RDCLP, or R: RDCLP	91	S: RDEP, or R: RDEP
62	S: CDS, or R: CDS	92	S: CDD, or R: CDD
63	S: CDC, or R: CDC	93	S: RDDP, or R: RDDP
64	S: CDPB, or R: CDPB	94	S: CDR, or R: CDR
65	S: RDPBP, or R: RDPBP	95	S: RDRP, or R: RDRP
70	S: CDUI, or R: CDUI (Data phase - layer 6 and facsimile data)	96	S: RDGR, or R: RDGR
		97	S: RDPBN, or R: RDPBN

3.3 LE DS

There are six LEDs on the G4 Interface board, as shown below.

		LED 5	LED 6
LED 1	LED 2	LED 3	LED 4

These LEDs give the following information about the status of the machine.

Initial Settings

O=ON, --=OFF

Power-up/Reset

		O	O
--	--	--	--

Initial setting request from FCU

		--	O
--	--	--	--

Initial setting confirmation to FCU

		--	--
--	--	--	--

Communication

Layer 1 activated

		--	--
O	--	--	--

Layer 2 set

		--	--
O	O	--	--

B channel connected (ISDN G4)

		--	--
O	O	O	--

B channel connected (ISDN G3)

		--	--
O	O	--	O

B channel released

		--	--
O	O	--	--

Layer 2 released

		--	--
O	--	--	--

Layer 1 deactivated

		--	--
--	--	--	--

The following will be displayed if bit 1 of G4 parameter switch E is at 1.

B channel: send I frame (A blinks at this time if bit 1 of G4 parameter switch E is at 1)

		--	A
O	O	O	--

B channel: receive I frame (B blinks at this time if bit 1 of G4 parameter switch E is at 1)

		B	--
O	O	O	--

Note: At the start and end of communication, both A and B will blink.

3.4 BACK-TO-BACK TEST

To make a back-to-back test, you need:

- Two machines (both of them must have a CiG4 board)
- Cross rosette

The procedure is as follows.

1. Switch off the machines
2. Connect two machines back-to-back using the cross rosette as follows.

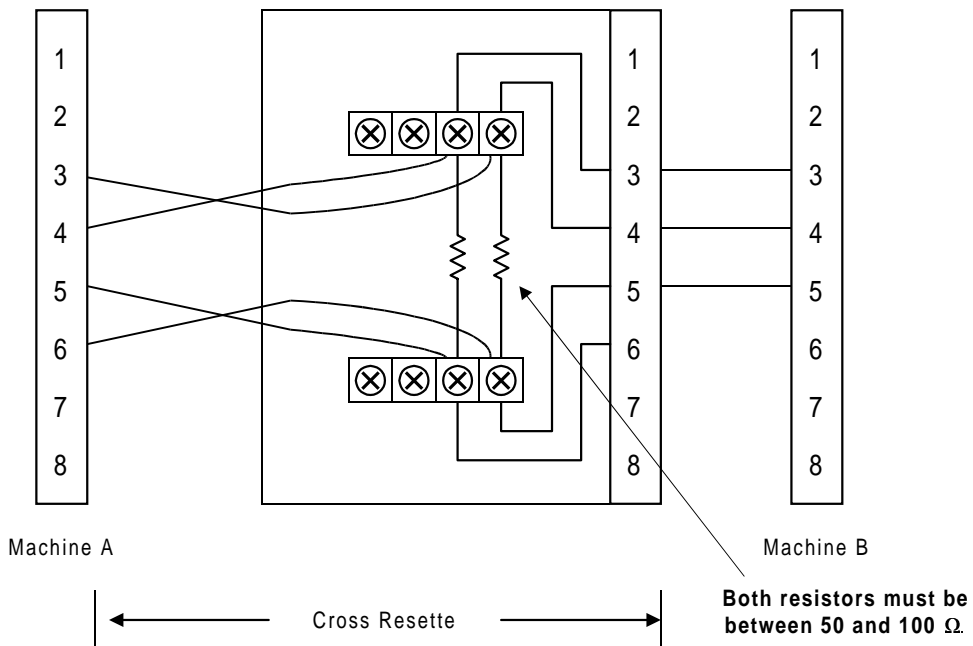

A890T501.WMF

3. Make the following bit switch adjustments:
 - In the machine acting in NT mode, set bits 0 and 1 of G4 parameter switch 0D to 1.
 - In the machine acting in TE mode, set bit 0 of G4 parameter switch 0D to 0 and bit 1 to 1.
4. Reset the machines by switching them off, waiting a few seconds, then switching back on.
5. Place a document in one of the machines, dial a number, then press Start.
6. After you have finished the test, set bits 0 and 1 of G4 parameter switch 0D back to 0, then reset the machine.

NOTE: The following cannot be tested using this procedure:

- ISDN G3 communication
- P to M